

# 3 Dimensional machine tool positioning accuracy

*Laser vector measurement vs. linear measurement*

By **Charles Wang**  
President  
Optodyne, Inc.

The increasing demand for accuracy of machined parts is being fueled by economics because it reduces assembly, warranty, and ownership costs. Traditionally, manufacturers have ensured accuracy of parts with linear (one-dimensional) calibration of the machine tools used for making them. But linear calibration is inadequate for ensuring accuracy of three dimensional parts. ASME B5.54 and ISO230-6 volumetric machine tool performance measurement standards were introduced. Because of the expense, necessitating the machine to be non-productive for two or three days, manufacturers have been reluctant to adopt volumetric calibration. However, the Laser Vector Technique for 3D volumetric calibration and compensation, developed by Optodyne Inc. using laser Doppler calibration equipment, is becoming popular because it reduces the time factor from two or three days to two or three hours.

Relying on linear calibration, one-dimensional measurements parallel to the axis of movement assume that the only possible errors are ballscrew and thermal expansion errors. But this ignores squareness errors, straightness errors, angular errors, and errors caused by non-rigid body motion. In fact, there are many large non-rigid body positioning errors caused by shifting weight and counter weight, etc. Carrying this to the extreme by using Taylor's linear expansion theory, two slope terms in the perpendicular directions can be added. As a result, for a 3-axis machine, there are 45 errors. Of course, not all of these nonrigid body error terms are important.

Because positioning accuracy of a machine tool is very complex, it has been simplified with various assumptions. For example, the rigid body as-

sumption, proposes six errors—one displacement error, two straightness errors and three angular errors—in the X, Y, and Z axes. For a 3-axis machine, there are 18 errors plus three for squareness, a total of 21 errors. Therefore to achieve higher positioning accuracy, the angular, straightness, and squareness errors must be measured and compensated.

Using the Laser Vector Technique, only four

body diagonal displacement measurements are needed to determine 3D volumetric accuracy. Body diagonal displacement errors are sensitive to all the volumetric error components and therefore make an efficient test of volumetric accuracy. The Laser Vector Technique measures all three displacement errors, three vertical straightness errors, and three horizontal straightness errors with just four setups.

The working volume of a typical VMC includes eight body diagonals, a diagonal being defined by starting at one corner of the base plane and mov-

ing to the opposite corner at the top plane. These body diagonals are defined by the positive or negative axis movement. The last four body diagonals are the same corners as the first four diagonals, except the directions are reversed. Hence there are only four body diagonal directions with forward movement and reverse movement (bi-directional), and only four setups.

For each setup, the machine spindle movement along each of the diagonals is measured by first executing X, Y and, Z portions of the spindle travel. Readouts are taken and recorded at each intermediate step for three displacement errors, three vertical straightness errors, and three horizontal straightness errors.

## Laser calibration

The two **primary** systems for linear displacement and volumetric calibration of machine tools and CMMs include the dual aperture laser interferometer system and the single aperture interferometer system. Both systems use lasers and optics, but they differ in how the data is collected and analyzed.

The dual aperture laser interferometer system is based on the Michelson

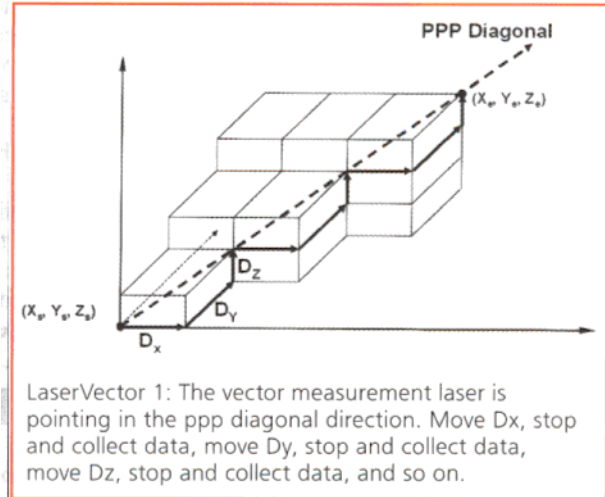

LaserVector 1: The vector measurement laser is pointing in the ppp diagonal direction. Move Dx, stop and collect data, move Dy, stop and collect data, move Dz, stop and collect data, and so on.

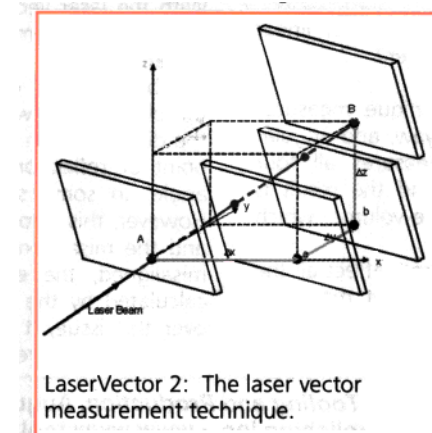

LaserVector 2: The laser vector measurement technique.

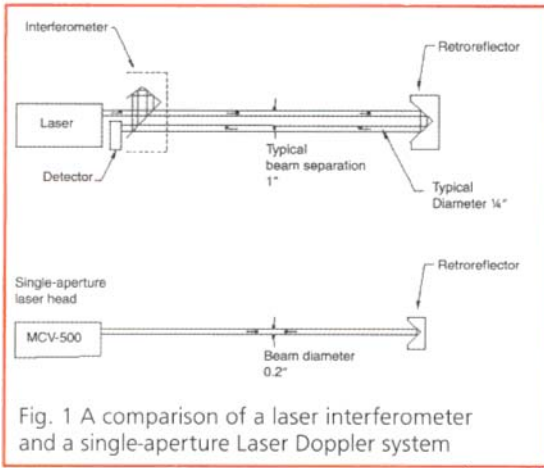

system is based on laser Dopplerometry. The laser head is very compact (2" x 2" x 8.5") and is completed with stabilization circuits, electrooptics, and photo-detectors. As shown in Fig. 1, the output beam and the return beam share the same aperture. A small retroreflector or a flat mirror can be used as target; as a result the laser system is very compact and versatile. The capability of using a flat-mirror as the

interferometer systems. For example, the single aperture interferometer system uses only two optics, a laser head and a retroreflector, making it much easier and faster to align and setup. Because the optics are much smaller, the whole system will fit in one large briefcase, making it easier to setup and transport. The single aperture interferometer system is the only system that can use a flat mirror as a target, which is required for the time-saving laser vector technique for 3D volumetric calibration.

interferometer. There are two laser beams, the output beam and the return beam, which are parallel but displaced about 1", as shown in Fig. 1. The two beams require large optics. Also, the alignment is critical because three elements have to be aligned co-axially, which increases setup time. The laser head of a dual aperture laser interferometer is large and heavy, a heavy tripod is required to support it.

The single-aperture Optodyne laser

target is very important for the laser vector technique. Since there are only two elements to be aligned, the alignment is not as difficult as the dual aperture laser interferometer. Also, the system is very compact and can be mounted on the machine tool, providing greater accuracy and eliminating the need to remove covers or dismantle the machine tool.

Significant differences exist between the dual aperture and single aperture

Regular volumetric calibration and compensation increase productivity, post effectiveness, and lead to shorter cycle times, better quality parts, less frequent repairs and lower warranty costs. With more quality control programs requiring calibration, the ability to utilize volumetric calibration and compensation will inevitably lead to more competitive and profitable manufacturing processes. **Optodyne Inc., 310-635-7481, www.optodyne.com**

## FAQ's

### Question:

When following ASME B5.54-1992 and ISO 230-6 calibration standards, can there be a situation where a machine tool is shown to achieve a good result even though it has poor volumetric performance?

### Answer:

The ASME 85.54-1992 and ISO 230-6 standards have been in use for a long time and their efficacy has been validated with empirical physical cutting tests for years. In theory, the only situation in which it's possible for volumetric performance to be poor and still show a good result is when there are linear displacement errors in X, Y and Z, and the other 18 angular, squareness, and straightness errors are 0. However, this is very unlikely because ASME 85.54-1992 and ISO 230-6 call for a minimum of 10 measurement points along the body diagonal between the two corners in 3D space. While it's possible the errors at all 10 points could be exactly the same and cancel each other out, it is a hypothetical situation with virtually no chance of being replicated in a real life.

### Question:

When using the sequential step and conventional linear techniques, can linear displacement error differ?

### Answer:

The conventional linear displacement technique measures only one edge and fails to consider pitch, yaw, and angular errors. The sequential step technique measures all four edges. The measurements are averaged and the result is displacement error through the center of the volume, which is inherently more accurate.

For example, pitch, yaw, and roll angular errors affect all the measurements, including the linear displacement measured by a conventional laser interferometer. Therefore, the linear displacement errors measured along the X-axis will be different

when measured at different Y and Z locations. This is because of different Abbe offsets at different locations and the pitch, yaw, and roll angular motions. This is the reason the 85.54 standard states all the linear displacement measurements must be along three orthogonal lines (parallel to the 3 axes) passing through the center of the working volume.

The advantage of the laser vector technique is positioning errors caused by angular errors are included in the measurement and expressed as the averaged straightness errors along the center lines of the working volume. This is important because most machine tools are unable to compensate for angular errors. If angular errors can't be compensated, the best work-around is to compensate for the averaged straightness errors. Of course, the displacement errors and straightness errors measured along one edge of the working volume will be different from those measured along another edge due to the Abbe offset and angular errors. This is the reason the Laser Vector Technique measures four errors and averages them.

### Question:

With the laser vector technique, if the mirror is misaligned, will the measurements be inaccurate?

### Answer:

No, because the error is a constant. Any misalignment of the plane mirror will cause an error, which is proportional to the distance from the original point of reflection to the new point of reflection on the mirror, times the misalignment angle. In some situations, this error may be very large. However, this error is a constant (the distance is a constant and the misalignment angle is a constant). If the mirror is misaligned, the error is a constant and is automatically calculated by the equipment. However, if there is concern over this issue, it takes only a few minutes to realign the mirror in the correct position.