

# 3D Volumetric Positioning Errors of CNC Machining Centers Theoretical Derivations and Laser Vector Measurement

Charles Wang and Jay Nilsson  
Optodyne, Inc.,  
Compton, California, USA  
[www.optodyne.com](http://www.optodyne.com)

and

Yang Jianguo  
Shanghai Jiao Tong University  
Shanghai, RPC

## Abstract

The worldwide competition and quality standards demanded tighter tolerance and regular maintenance of all machine tools. To generate good quality or accurate parts, the true 3 dimensional volumetric positioning accuracy of a machine tool is critical. However, because the measurement of 21 rigid body errors is very difficult and time consuming, for most machine tools only linear displacement errors were measured.

The introduction of B5.54 and ISO230-6 machine tool performance measurement standards are increasing the popularity of laser interferometer diagonal displacement error measurement and the sequential step diagonal or laser vector measurement for the calibration and compensation of machine tool volumetric positioning errors. To establish the theoretical bases for the 4 body diagonal displacement measurement, it is important to derive the relations of the 21 rigid body errors and the measured 4 body diagonal displacement errors. For these purposes, the formulae for the 3D volumetric positioning errors of CNC machining centers in 4 basic configurations have been derived by using the third order translation and rotation matrices. The 3D volumetric positioning errors have also been measured and compensated by the laser vector technique.

Reported here are derivations of the 4 body diagonal displacement errors in 2 of the popular machine configurations, XFYZ (horizontal machining centers), and XYFZ (vertical machining centers), and the measurement of these errors using the laser vector technique. Based on these formulae, the advantages and limitations of the 4 body diagonal displacement measurements have been analyzed. It is concluded that, the 4 body diagonal displacement errors is a good measure of the 3D volumetric positioning accuracy. The 3D volumetric position errors of a CNC machining center can be measured and compensated to achieve high positioning accuracy. The theoretical derivation and the measurement results will be discussed.

**Key words:** Body Diagonal, Sequential Step diagonal, Volumetric errors, Machine calibration, Compensation, Laser interferometer, and rigid body errors.

---

Presented in the International Dimensional Workshop, Nashville, TN, May 9-13, 2005.

## **I. Introduction**

Worldwide competition and quality standards such as ISO 9000 and QS 9000, demanded tighter tolerance and regular maintenance of all machine tools. Twenty years ago, the largest machine tool positioning errors are lead screw pitch error and thermal expansion error. Now, most of the above errors have been reduced. The largest machine tool positioning errors become squareness errors and straightness errors. Hence, to achieve higher 3D volumetric positioning accuracy, all 3 displacement errors, 6 straightness errors and 3 squareness errors have to be measured and compensated.

Using a conventional laser interferometer to measure the straightness and squareness errors is rather difficult and costly. It usually takes days of machine down time and experienced operator to perform these measurements. For those reasons the body diagonal displacement error defined in the ASME B5.54 or ISO 230-6 standard is a good quick check of the volumetric error. Furthermore, since the performance of these measurements is relatively simple, fast and straight forward without incurring high costs and long machine down time, it has been used by Boeing Aircraft Company and many others for many years with very good results and success. However, it is not clear, what are the relations between the body diagonal displacement errors and the 3D positioning errors. Also, questions have been raised as whether the angular errors are important in the body diagonal displacement measurement.

To establish a theoretical foundation, the relations of the 21 rigid body errors and the measured 4 body diagonal displacement errors have been derived. The result shows that for the XFYZ and XYFZ configurations or horizontal and vertical machining centers respectively, most of the angular errors are cancelled and only 2 angular error terms are left. Hence the 4 body diagonal displacement measurement is a measure of 3 displacement errors, 6 straightness errors, 3 squareness errors, and is not sensitive to angular errors. It is indeed a good and quick measure of the 3D volumetric positioning accuracy.

Recently, Optodyne has developed a new revolutionary laser vector measurement technique (US Patent 6,519,043, 2/11/2003) for the 3D volumetric positioning error measurement. The measurement can be performed in a few hours instead of a few days by a conventional laser interferometer. Hence the 3D volumetric calibration and compensation become practical, and enable higher accuracy and tighter tolerance to be achieved.

## **II. 21 rigid body errors and 4 machine configurations**

For a 3-axis machine, there are 6 errors per axis or a total of 18 errors plus 3 squareness errors. These 21 rigid body errors [4] can be expressed as the following.

Linear displacement errors:  $D_x(x)$ ,  $D_y(y)$ , and  $D_z(z)$

Vertical straightness errors:  $D_y(x)$ ,  $D_x(y)$ , and  $D_x(z)$

Horizontal straightness errors:  $D_z(x)$ ,  $D_z(y)$ , and  $D_y(z)$

Roll angular errors:  $A_x(x)$ ,  $A_y(y)$ , and  $A_z(z)$

Pitch angular errors:  $A_y(x)$ ,  $A_x(y)$ , and  $A_x(z)$

Yaw angular errors:  $A_z(x)$ ,  $A_z(y)$ , and  $A_y(z)$

Squareness errors:  $\emptyset_{xy}$ ,  $\emptyset_{yz}$ ,  $\emptyset_{zx}$ ,

where, x, y, z are the coordinates, D is the linear error, subscript is the error direction and the position coordinate is inside the parenthesis, A is the angular error, subscript is the axis of rotation and the position coordinate is inside the parenthesis.

In most cases, coordinate measuring machines CMM and machine tools can be classified into four configurations [5]. They are the FXYZ, XFYZ, XYFZ, and XYZF. Here, the axis before F show available motion directions of the work piece with respect to the base, and the letters after F show the available motion directions of the tool (or probe) with respect to the base. For example, in FXYZ the work piece is fixed, and in XYZF the tool is fixed.

### III. Body diagonal displacement errors

The body diagonal displacement measurement method is recommended for a fast examination of the positioning and geometrical performances of the machine in all its components. Practically it is the measurement of the volumetric positioning accuracy by a laser interferometer. A retroreflector is mounted on the spindle and illuminated by the laser beam, which is aligned along the machine diagonal, for example from the lower left corner ( $X=0$   $Y=0$   $Z=0$ ) to the upper right corner ( $X_{max}$ ,  $Y_{max}$ ,  $Z_{max}$ ). Starting from the zero position and at each increment of the three axes, which are moved together to reach the new position along the diagonal, the displacement error is measured. It is obvious, the accuracy of each position along the body diagonal depends on the positioning accuracy of all three axes and the machine geometrical errors. Hence the body diagonal displacement measurement is a good method for the machine verification, but there is not enough information for the identification of the error sources.

For the 4 body diagonal displacement measurement [1, 2], the measurement directions are ag, bh, ce, and df, as shown in Fig. 1. The measurement is performed with the laser pointing along the body diagonal direction and the retroreflector moving along the body diagonal with a fixed increment as shown in Fig. 2.

To derive the relations between the actual position and the commanded position, a third order vector and matrix method were used [6]. The vector positions of each stage,  $\mathbf{X}$ ,  $\mathbf{Y}$  and  $\mathbf{Z}$  can be expressed as column vectors,

$$\mathbf{X} = \begin{Bmatrix} x + Dx(x) \\ Dy(x) \\ Dz(x) \end{Bmatrix}$$

$$\mathbf{Y} = \begin{Bmatrix} Dx(y) \\ y + Dy(y) \\ Dz(y) \end{Bmatrix}$$

$$\mathbf{Z} = \begin{Bmatrix} Dx(z) \\ Dy(z) \\ z + Dz(z) \end{Bmatrix}$$

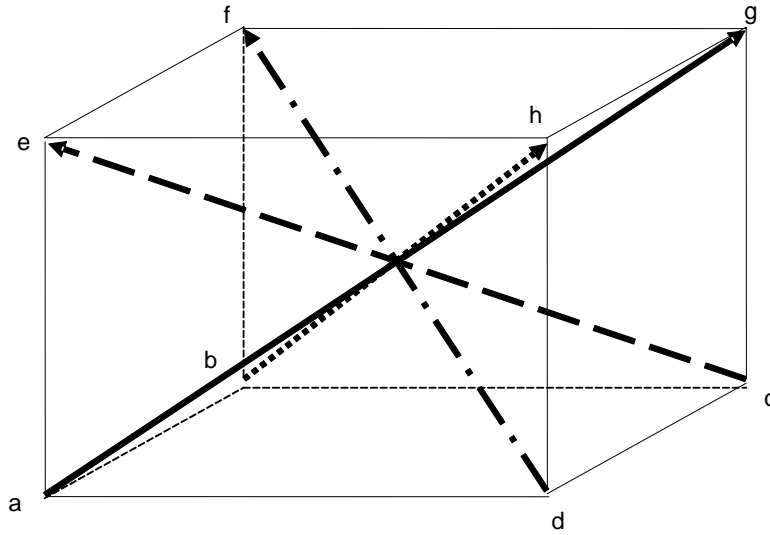

Fig. 1, The 4 body diagonal directions.

**Body Diagonal Measurement**

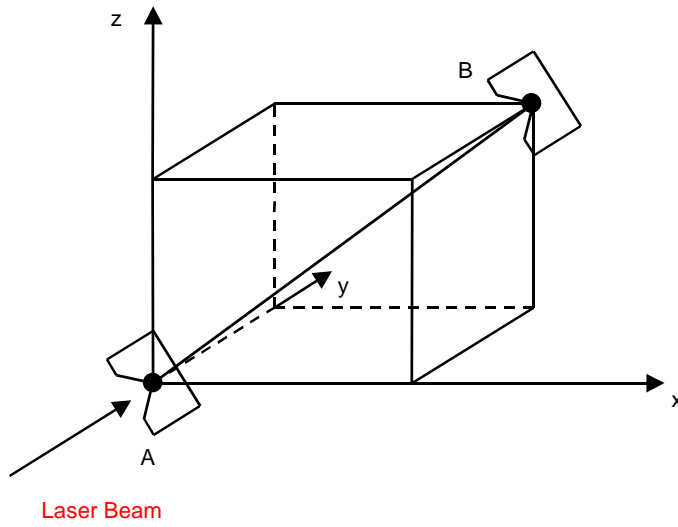

Fig. 2, The laser beam direction and the retroreflector

To simplify the calculation, the squareness errors are included in the straightness errors.

The tool offset can be expressed as a column vector,

$$\mathbf{T} = \begin{Bmatrix} \mathbf{X} \\ \mathbf{Y} \\ \mathbf{Z} \end{Bmatrix}.$$

The angular error matrix can be expressed as,

$$\mathbf{R}(u) = \begin{Bmatrix} 1, & Az(u), & -Ay(u) \\ -Az(u), & 1, & Ax(u) \\ Ay(u), & -Ax(u), & 1 \end{Bmatrix},$$

where  $u = x, y$  or  $z$ .

Since the positions of the X, Y, and Z stages are represented by the vectors **X**, **Y**, and **Z** respectively, the angular errors of the X, Y, and Z stages are represented by the angular error matrices **R(x)**, **R(y)**, and **R(z)**, the offset of the tool tip (or probe) are represented by the vector **T(X, Y, Z)**, as shown in [6] the actual positions **P** with respect to the work piece or machine coordinate can be expressed in the following equations.

$$\text{For XFYZ: } \mathbf{P} = \mathbf{R}(x)\mathbf{X} + \mathbf{R}(x)\mathbf{Y} + \mathbf{R}(x)\mathbf{R}(y)\mathbf{Z} + \mathbf{R}(x)\mathbf{R}(y)\mathbf{R}(z)\mathbf{T} \quad (1)$$

$$\text{For XYFZ: } \mathbf{P} = \mathbf{R}(y)\mathbf{R}(x)\mathbf{X} + \mathbf{R}(y)\mathbf{Y} + \mathbf{R}(y)\mathbf{R}(x)\mathbf{Z} + \mathbf{R}(x)\mathbf{R}(y)\mathbf{R}(z)\mathbf{T} \quad (2)$$

The actual tool tip position can be expressed as a column vector,

$$\mathbf{P} = \begin{Bmatrix} P_x \\ P_y \\ P_z \end{Bmatrix}.$$

For XYFZ configuration, Eq. (2) becomes,

$$\begin{aligned} P_x - x &= [Dx(x) + z^*Ay(x)] + [Dx(y) - y^*Az(y) + z^*Ay(y)] + [Dx(z)] \\ P_y - y &= [Dy(x) + x^*Az(x) - z^*Ax(x)] + [Dy(y) + x^*Az(y) - z^*Ax(y)] \\ &\quad + [Dy(z)] \\ P_z - z &= [Dz(x) - x^*Ay(x)] + [Dz(y) - x^*Ay(y) + y^*Ax(y)] + [Dz(z)]. \end{aligned} \quad (3)$$

Additional errors caused by a tool offset of X, Y, and Z are,

$$\begin{aligned} P_{tx} &= X + [-Y^*Az(x) + Z^*Ay(x)] + [-Y^*Az(y) + Z^*Ay(y)] \\ &\quad + [-Y^*Az(z) + Z^*Ay(z)] \\ P_{ty} &= Y + [X^*Az(x) - Z^*Ax(x)] + [X^*Az(y) - Z^*Ax(y)] \\ &\quad + [X^*Az(z) - Z^*Ax(z)] \\ P_{tz} &= Z + [-X^*Ay(x) + Y^*Ax(x)] + [-X^*Ay(y) + Y^*Ax(y)] \\ &\quad + [-X^*Ay(z) + Y^*Ax(z)] \end{aligned} \quad (4)$$

For the body diagonal displacement errors, the measured error DR at each increment can be expressed as:

$$DR_{ppp} = a/r * Dx(x) + b/r * Dy(x) + c/r * Dz(x)$$

$$\begin{aligned}
& + a/r*[Dx(y) + y \emptyset_{xy}] + b/r*Dy(y) + c/r*Dz(y) \\
& + a/r*[Dx(z) + z \emptyset_{zx}] + b/r*[Dy(z) + z \emptyset_{yz}] + c/r * Dz(z) \quad (5) \\
& + Az(x)*ab/r - Ax(x)*bc/r.
\end{aligned}$$

$$\begin{aligned}
DRnpp = & -a/r * Dx(x) + b/r * Dy(x) + c/r * Dz(x) + \\
& - a/r*[Dx(y) + y \emptyset_{xy}] + b/r*Dy(y) + c/r*Dz(y) \\
& - a/r*[Dx(z) + z \emptyset_{zx}] + b/r*[Dy(z) + z \emptyset_{yz}] + c/r * Dz(z) \quad (6) \\
& - Az(x)*ab/r - Ax(x)*bc/r.
\end{aligned}$$

$$\begin{aligned}
DRpnp = & a/r * Dx(x) - b/r * Dy(x) + c/r * Dz(x) \\
& + a/r*[Dx(y) + y \emptyset_{xy}] - b/r*Dy(y) + c/r*Dz(y) \\
& + a/r*[Dx(z) + z \emptyset_{zx}] - b/r*[Dy(z) + z \emptyset_{yz}] + c/r * Dz(z) \quad (7) \\
& + Az(x)*ab/r - Ax(x)*bc/r.
\end{aligned}$$

$$\begin{aligned}
DRppn = & a/r * Dx(x) + b/r * Dy(x) - c/r * Dz(x) \\
& + a/r*[Dx(y) + y \emptyset_{xy}] + b/r*Dy(y) - c/r*Dz(y) \\
& + a/r*[Dx(z) + z \emptyset_{zx}] + b/r*[Dy(z) + z \emptyset_{yz}] - c/r * Dz(z) \quad (8) \\
& - Az(x)*ab/r - Ax(x)*bc/r.
\end{aligned}$$

where the subscript ppp means body diagonal with all x, y and z positive; npp means body diagonal with x negative, y and z positive; pnp means body diagonal with y negative, x and z positive; and ppn means body diagonal with z negative, x and y positive. Also a, b, c and r are increments in x, y, z, and body diagonal directions respectively. The body diagonal distance can be expressed as  $r^2 = a^2 + b^2 + c^2$ .

The 4 body diagonal displacement errors, shown in Eqs. 5 to 8, are sensitive to all of the 9 linear errors and two angular errors. The errors in the above equations may be positive or negative and they may cancel each other. However, the errors are statistical in nature, the probability that all of the errors will be cancelled in all of the positions and in all of the 4 body diagonals are theoretically possible but very unlikely. Furthermore, since most of the angular error terms are cancelled and only 2 angular error terms,  $Az(x)*ab/r$  and  $-Ax(x)*bc/r$  are left, we can conclude that the body diagonal displacement errors are not sensitive to angular errors. It is concluded that, the 4 body diagonal displacement measurement includes 3 displacement errors, 6 straightness errors, 3 squareness errors and is not sensitive to angular errors. It is a good and quick measure of the 3D volumetric positioning accuracy.

It is noted that, because there are only 4 sets of data and 9 sets of errors, we do not have enough information to determine the source of errors. To solve this problem, the sequential step diagonal measurement or laser vector technique [3] was developed by Optodyne to collect 12 sets of data with the same 4 diagonal setups. Based on these measurement data, all 3 displacement errors, 6 straightness errors and 3 squareness errors can all be determined. Hence 3D volumetric positioning errors can be measured without incurring high costs and long machine tool down time. Furthermore, the measured positioning errors can also be used to generate a 3D volumetric compensation table to correct the positioning errors and achieve higher positioning accuracy.

#### IV. Sequential step diagonal displacement measurement.

The new vector measurement method or Sequential Step Diagonal Measurement Method differs from the body diagonal displacement measurement by that each axis is moved separately in sequence and the diagonal positioning error is collected after each single movement of the X axis, of the Y axis and than of the Z axis. For this reason, 3 times more data is collected and also the positioning error due to each single axis movement can be separated [3,7].

In the conventional body diagonal displacement measurement, the target trajectory is a straight line and it is possible to use the corner cube as target that can tolerate a small lateral displacement. In the vector method, the movement is alternatively along the X axis, than along the Y axis and than along the Z axis, and repeated until the opposite corner of the diagonal is reached. As shown in Fig. 3, the trajectory of the target is not a straight line and the lateral movement is quite large. Hence it is not possible to use a conventional interferometer which cannot tolerate such large lateral movement. A laser interferometer with single aperture as shown in Fig. 4, is used with a flat mirror as target. It is noted that with a flat mirror as target, the movement parallel to the mirror do not displace the laser beam and do not change the distance from the source so the measurement is not influenced. Hence, it measures the movement along the beam direction and tolerates a large lateral movement of the target as shown in Fig. 5.

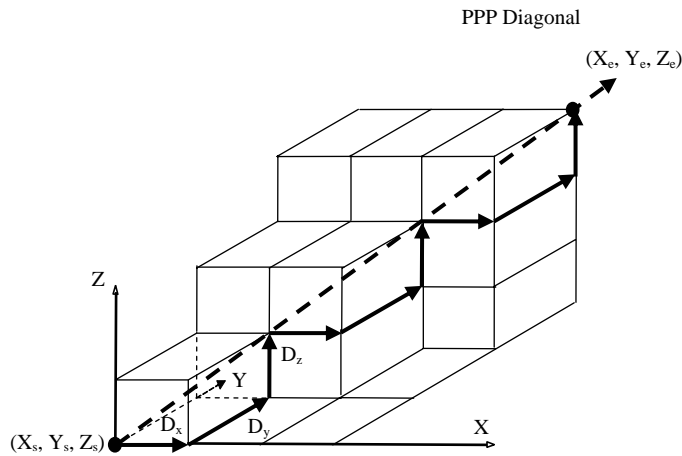

Fig. 3, The vector measurement, laser is pointing in the ppp diagonal direction and sequence is moving x-axis, stop, collect data, moving y-axis, stop, collect data, moving z-axis, stop, collect data and continue.

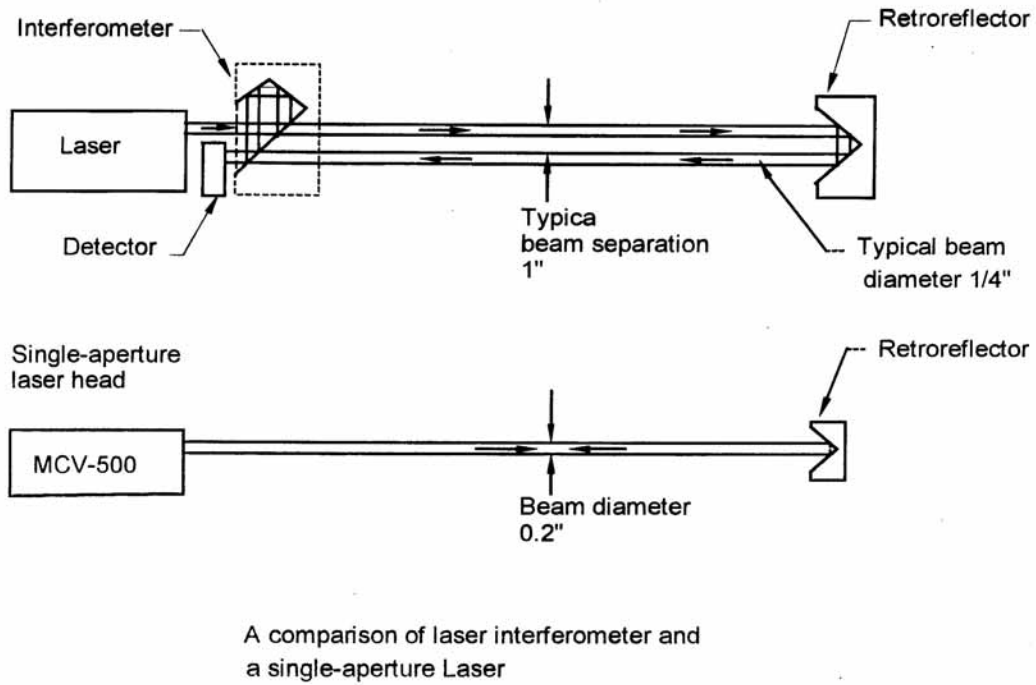

Fig. 4, Laser interferometers with dual apertures and single aperture.

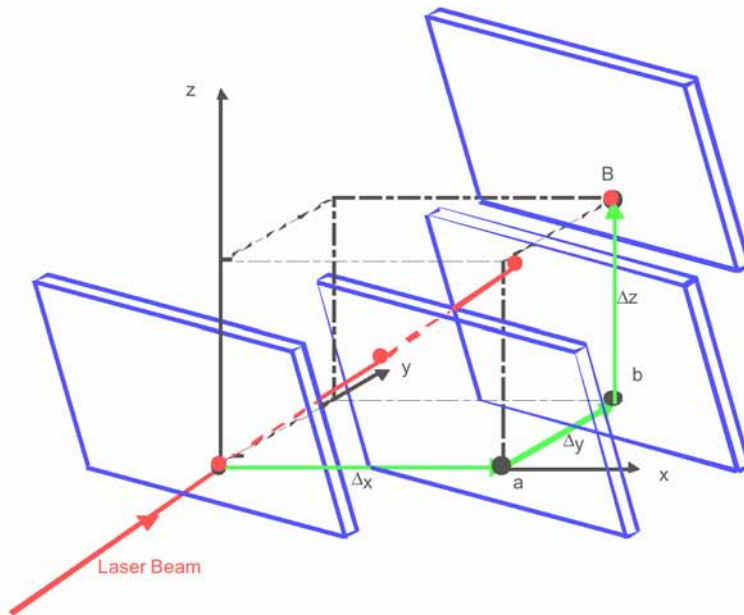

Fig. 5, Flat-mirror target positions correspond to x-axis movement, y-axis movement and z-axis movement.



The laser calibration system used is a Laser Doppler Displacement Meter (LDDM), OPTODYNE model MCV-500 with SD-500 sequential diagonal measurement accessory. It is a newest generation laser Doppler displacement meter (LDDM) with a single aperture. The system is completed with a steering mirror to easily align the laser beam in the body diagonal direction. The laser was mounted on the machine table and using a steering mirror to align the laser beam parallel to the body diagonal. The 3"x 4" (75×100mm) flat mirror was mounted on the spindle with the surface perpendicular to the laser beam. The machine was programmed to move the spindle starting from one corner to the opposite corner. The Air temperature and pressure were measured to compensate the changes in speed of light and the machine temperature was measured to compensate the machine thermal expansion.

The measurement data were automatically collected by the Windows LDDM software at every machine stop. The data was analyzed by the LDDM software and the errors for each axis were automatically calculated. Based on these errors the volumetric compensation file can be generated automatically. Two sets of body diagonal displacement data were collected, one without volumetric compensation and one with volumetric compensation. Linear displacement errors of each axis with the volumetric compensation were also measured.

## **V. Test setup and results**

We have performed the vector measurement on a Cincinnati vertical machining center. The measured volume were X = 55" (1397 mm) to 139" (3530.6 mm), Y = 2" (50.8 mm) to 50" (1270 mm) and Z = 10.5" (266.7 mm) to 34.5" (876.3 mm). The controller is Fanuc 16 i. There were 4 setups, one on each body diagonal directions, namely, ppp, npp, pnp, and nnp 4 directions. Based on the measured sequential step diagonal data, the volumetric positioning errors, including 3 displacement errors, 6 straightness errors and 3 squareness errors were determined.

The measured squareness errors are  $XY = -5.72$  arcsec,  $YZ = 1.73$  arcsec and  $ZX = 3.47$  arcsec. The measured linear displacement errors, vertical straightness and horizontal straightness of X-axis, Y-axis and Z-axis are shown in Figs. 6a, 6b, and 6c respectively. For X-axis, the maximum vertical straightness error (deviation in the y-direction) is +0.00035" (0.009 mm); the maximum horizontal straightness error (deviation in the z-direction) is - 0.0005" (0.0127 mm); and the maximum displacement error is - 0.0005" (0.0127 mm).

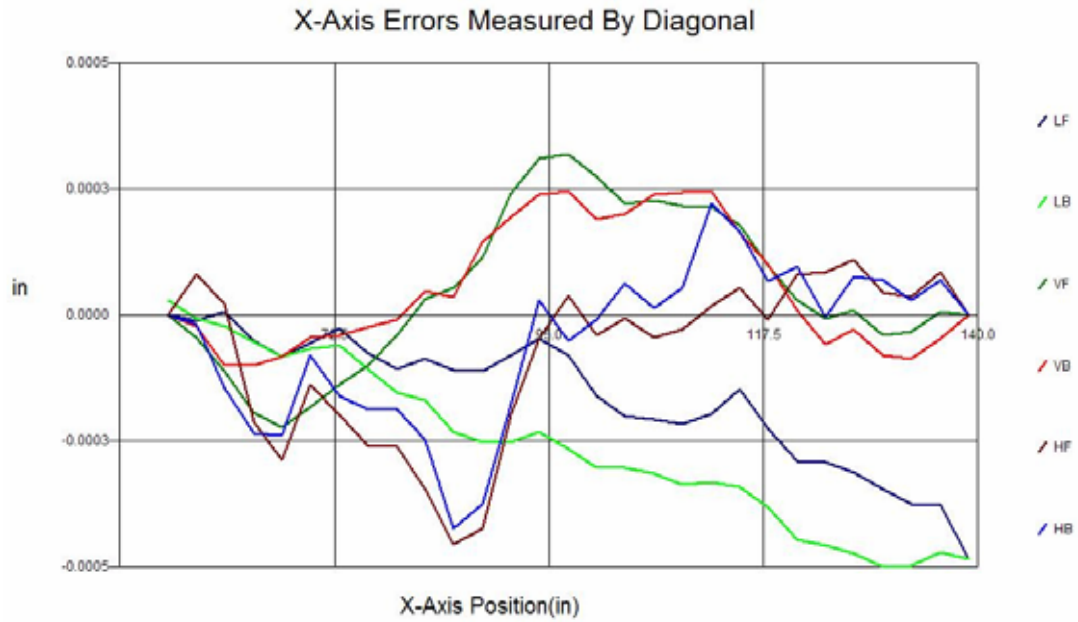

Fig. 6a, X-axis displacement errors (LF), vertical straightness errors (deviation in the y-direction VF) and horizontal straightness errors (deviation in the z-direction HF) measured by the vector method.

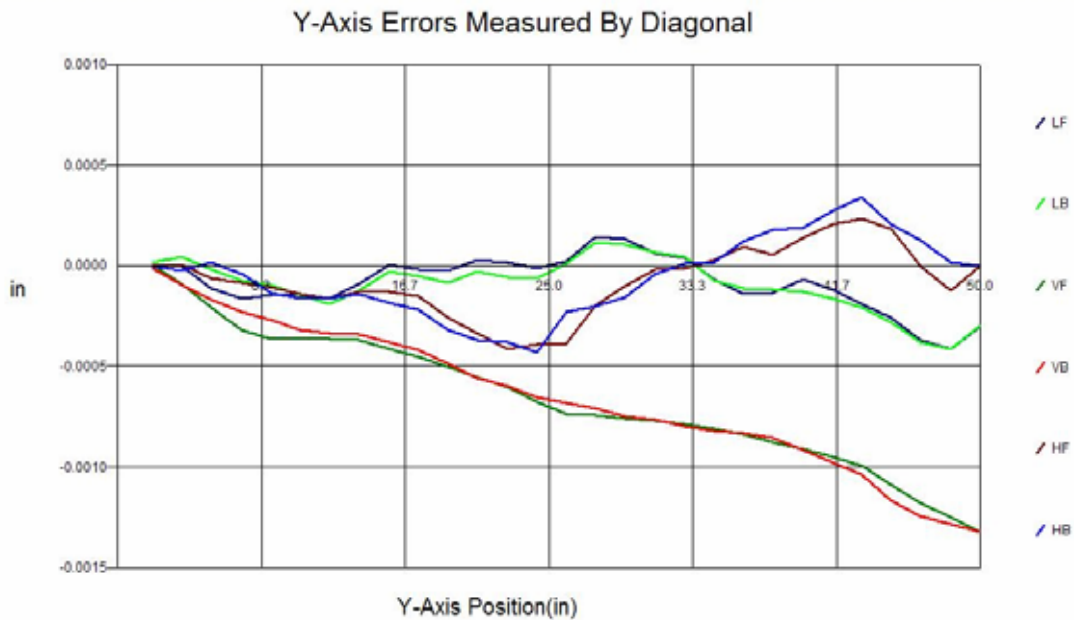

Fig. 6b, Y-axis displacement errors (LF), vertical straightness errors (deviation in the x-direction VF) and horizontal straightness errors (deviation in the z-direction HF) measured by the vector method.

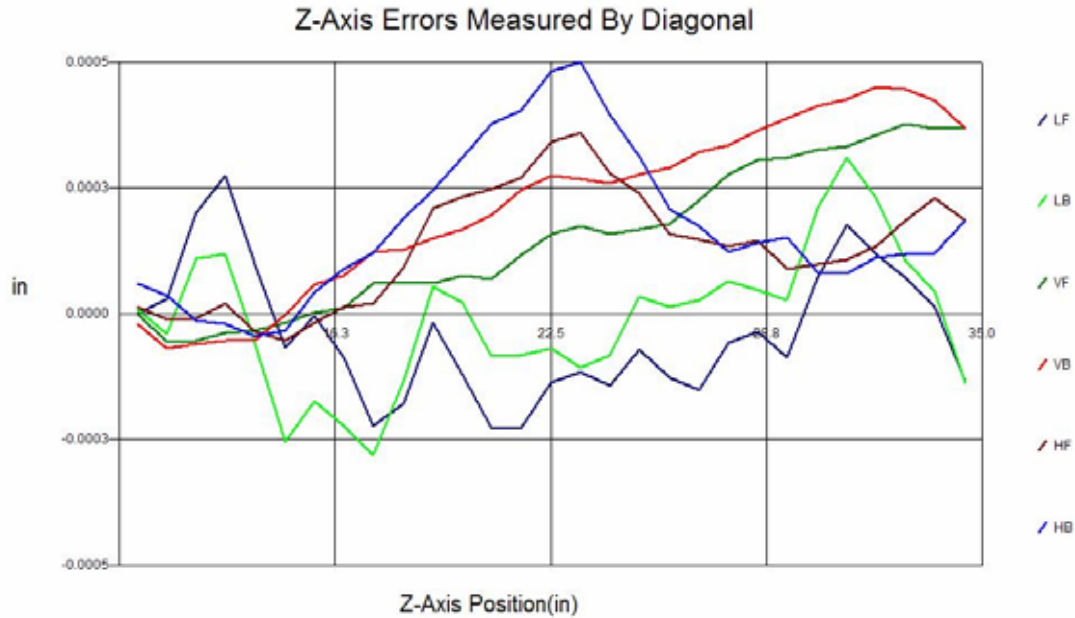

Fig. 6c, Z-axis displacement errors (LF), vertical straightness errors (deviation in the x-direction VF) and horizontal straightness errors (deviation in the y-direction HF) measured by the vector method.

For Y-axis, the maximum vertical straightness error (deviation in the x-direction) is 0.0002”/-0.0004” (0.0051mm/-0.0102mm); the maximum horizontal straightness (deviation in the z-direction) is 0.0035”/-0.004” (0.0889mm/-0.0102mm); and the maximum displacement error is - 0.0013” (-0.0330 mm).

For Z-axis, the maximum vertical straightness error (deviation in the x-direction) is 0.0005” (0.0127 mm); the maximum horizontal straightness error (deviation in the y-direction) is 0.00055” (0.0140 mm); and the maximum displacement error is -0.0015” (-0.0381 mm).

The measured ASME B5.54 or ISO 230-6 body diagonal displacement errors without compensation are shown in Fig. 7a. The maximum error is 0.003” (0.0762 mm). Using the laser sequential step diagonal data and the calculated volumetric positioning errors, the straightness error compensation table for the Fanuc 16 Controller was generated. The linear displacement errors of each axis were measured with the volumetric compensation. The measured maximum errors were 0.0002” (0.0051 mm), 0.0001” (0.00254 mm) and 0.0001” (0.00254 mm) for X-, Y-, and Z-axis respectively. These errors are considerable less than without volumetric compensation. With the volumetric compensation, the squareness errors are XY = - 0.05 arcsec, YZ = - 3.7 arcsec and ZX = -0.32 arcsec. The squareness errors are much less than without volumetric compensation. The body diagonal displacement errors with volumetric compensation are shown in Fig. 7b. The maximum error is 0.0006” (0.0152 mm), an improvement of 500%.

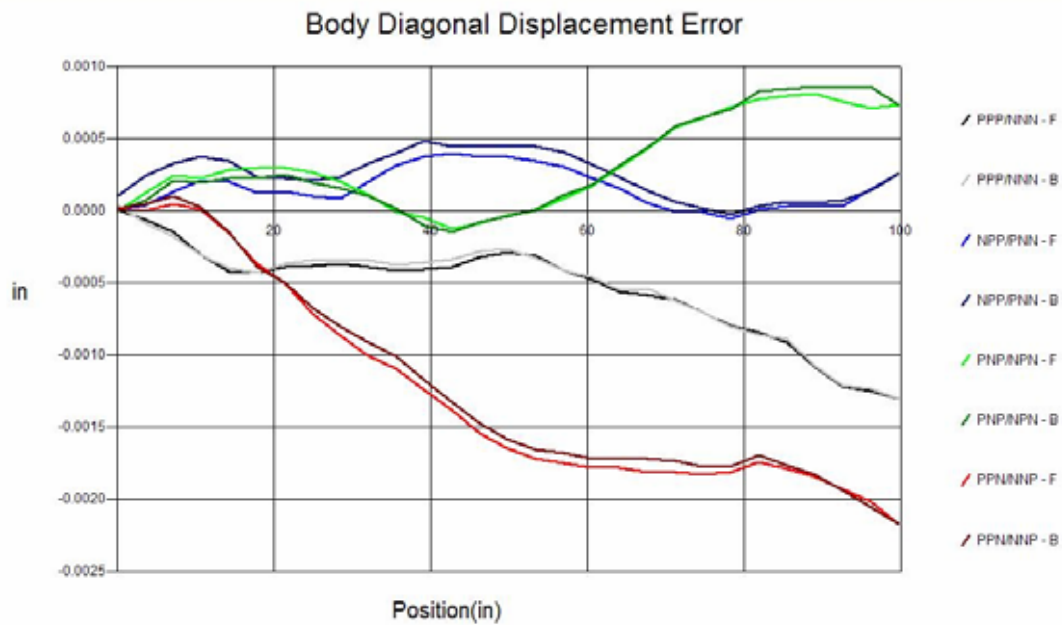

Fig. 7a, ASME B5.54 or ISO 230-6 body diagonal displacement errors. The maximum error is 0.018 mm.

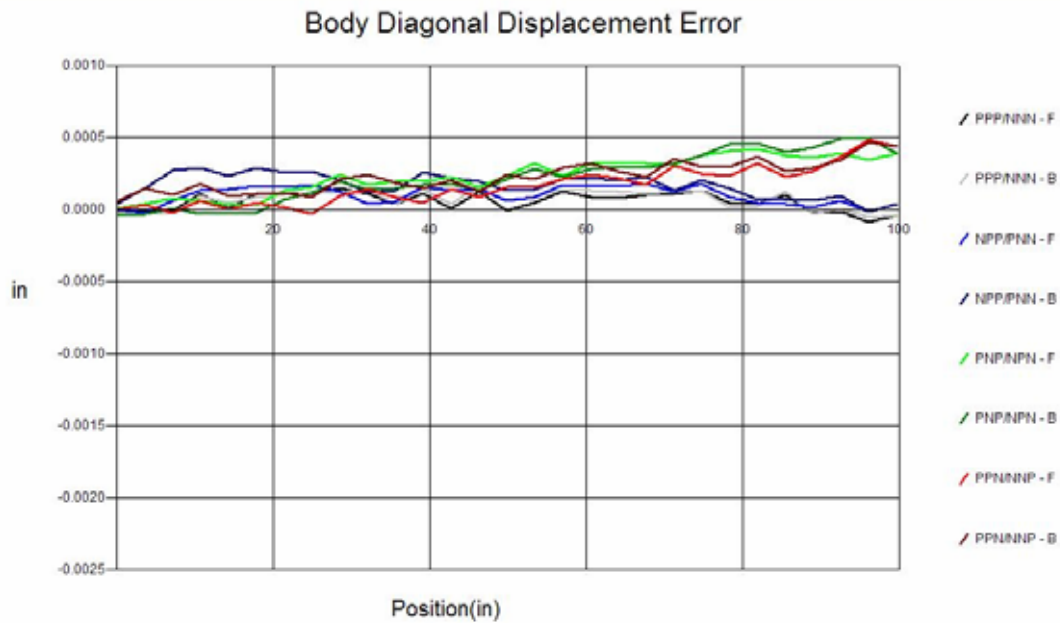

Fig. 7b, ASME B5.54 or ISO 230-6 body diagonal displacement errors with 3D volumetric positioning error compensation. The maximum error is 0.007 mm, an improvement of 250%

## VI. Summary and conclusion

In summary, for the XFYZ and XYFZ configurations, there are only 2 angular error terms. Hence the body diagonal displacement measurement is not sensitive to angular errors. It is a good quick check of the volumetric positioning errors, namely the 3 displacement errors, 6 straightness errors and 3 squareness errors. The sequential step diagonal measurement collects 12 sets of data to solve for all the 9 linear errors and 3 squareness errors. The measured volumetric positioning errors can be used to generate the volumetric compensation file and reduce the body diagonal displacement error considerably. Hence the calibration and compensation of 3D volumetric positioning errors of CNC machining centers or CMM become viable and practical.

## References

- [1] Methods for Performance Evaluation of Computer Numerically Controlled Machining Centers, *An American National Standard*, ASME B5.54-1992 by the American Society of Mechanical Engineers, p69, 1992.
- [2] ISO 230-6: 2002 Test code for machine tools – Part 6: Determination of positioning accuracy on body and face diagonals (Diagonal displacement tests)”, *an International Standard*, by International Standards Organization, 2002.
- [3] Wang, C., Laser Vector measurement Technique for the determination and compensation of volumetric positioning errors. Part I: Basic theory, *Review of Scientific Instruments*, Vol. 71, No 10, pp 3933-3937, 2000.
- [4] Schultschik, R., The components of the volumetric accuracy, *Annals of the CIRP*, Vol.25, No.1, pp223-228, 1977.
- [5] Zhang, G., Quang, R., Lu, B., Hocken, R., Veale, R., and Donmez, A., A displacement method for machine geometry calibration, *CIRP*, Vol. 37, No 1, pp515-518, 1988.
- [6] Yang, J., Ren, Y., Wang, C., and Liotto, G., Theoretical Derivations of 4 Body Diagonal Displacement Errors in 4 Machine Configurations, Proceedings of the 7<sup>th</sup> LAMDAMAP Conference, Cransfield, England, June 27, 2005.
- [7] Wang, C. and Liotto, G., A Theoretical Analysis of 4 Body Diagonal Displacement Measurement and Sequential Step Diagonal Measurement, Proceedings of the 6<sup>th</sup> LAMDAMAP Conference, Huddersfield, England, July 4, 2003.